

Information about the printing of CDs and DVDs

Terms

- Silk-screen printing:** A printing technique. The printing ink is pressed through a screen onto the printed surface.
Here it refers to the printing of images on a CD or DVD across a template prepared from fabrics treated with a photosensitive emulsion or capillary film. In printing terminology this is “a stencil printing technique”, namely the “smear stencil printing”.
- Half-tone printing:** It is the break-up of an image into a large number of dots.
- Screening:** The dots or other geometrical shapes, into which an image is broken up.
- Screening density:** Means the number of half-tone dots in a unit of length, usually in 1 cm or 1 inch, for example 120 lpi (120 lines per inch, equals to 48 lines per centimetre).
- Density (mask, saturation, richness):**
A result of the size of the half-tone dots: the proportion of the surface left uncovered to the surface covered by the dots. The density is the ratio of the surface covered by dots to the total available surface at 100% coverage. This ratio is expressed as a percentage.
- Colour printing (C,M,Y,K)** The printing of colour images by accurate register printing of elementary or complementary colours. In silk-screen printing, the EURO colorimetric scale is used: it has three colour components, cyan **C**, magenta **M**, and yellow **Y**. There is a fourth colour, black **K**: it is a three- or, if black is used, a four-colour printing technique.
- Direct printing:** Printing directly with the inks of the PANTONE SYSTEM.
- Register:** The accurate overlapping of print elements during colour printing. In order to achieve an accurate register with the available modular screen-printing technology, it is necessary to achieve in the printing motifs the so-called colour trapping.
- Colour trapping:** When the coloured areas of different plates overlap on the surface of a colour print. This information must be provided for the preparation of the printons in the DTP studio.
- Moiré:** A disruptive pattern occurring when two regular patterns or waves are superimposed while their frequencies are very similar. If two sample periods coincide, e.g., at each tenth wave, a new wave emerges with a regular pattern occurring at ten times the frequency of the initial waves. The visual impact of the new pattern will be ten times more disruptive. This results in an effect reminding of a view through transparent chequered fabric.

- Chromalin:** A type of chemical proof used for checking the accuracy of a registration and the quality of the colours on the printed material.
- Bleed:** Image elements printed in the “bleed” fall outside the printable area and are partially cut off from the printed object when trimming.

At GZ Digital Media, we use the silk-screen and offset printing technologies to print the CD and DVD labels.

Technical specifications – silk-screen

Available:

- From 1 to 5 spot- ("direct") colours (the 6th colour is also available at the price of certain capacity limitations), including one background colour covering the entire surface of the print.
- Half-tone printing.
- Four-colour printing over a background colour.

1. Attainable coverage (density)

In comparison with “offset printing”, the silk-screen prints have a more visible relief. This is due to the greater quantity of ink applied on the screen in comparison with an offset printing, where a thin application of ink and the flat printing technique allow for colour densities below 5% and over 90%. The results of silk-screen printing are influenced by the screen used, by the capillary film and by the quantity of ink applied.

When a plate is prepared, the print-on screening dots are detailed onto the screen of the stencil. To print a light hue, the ink must be pressured through very small holes in the stencil. Some of those points are covered by the fibres of the netting, and no ink is applied. This is why at very light values a screening dot deficit can occur; there is a lower limit of about 15% to the achievable saturation values.

Conversely, when printing at a high density, the points in the stencil are so close one to another that they tend to combine into large surfaces or stains. This limits the maximum density to around 85%.

As a result, it is necessary to plan half-tone prints with levels of opacity not falling below 15% or above 85%!!!! Moreover, abrupt density changes must be avoided (e.g. artist on stage under spotlight, etc.).

If this is unavoidable in the selected artwork, corrections will have to be made during the preparation of the film at the DTP studio.

To achieve gradual shifts in colour density, you must select the right screening dot shape (and specify that information to the DTP studio). The most appropriate screening dot appears to be the autotypic 70/30 ellipsoidal dot. Abrupt density changes may be corrected by tuning down the basic colours C, M, Y. However, this also leads to shifts in colour shades on that particular area of the print.

2. Half-tone used:

Silk-screening uses amplitude-modulation of screening. (Frequency-modulation is not used because it would involve too fine screening.) Half-tone printing resolution depends on the netting used for the screen. There are important limitations in the choice of a screening

resolution. If the wrong resolution is chosen, there is a high risk of moiré between the screening of the film and the pattern of the screen.

Half-tone printing requires an autotypic (amplitude) screening of 120 lpi (= 48 l/cm).

3. Half-tone dot shapes:

With half-tone printing, the shape of the dot has the greatest impact on the appearance of the print. This must be kept in mind at the time of choosing a dot shape for converting the image.

Selected types of dots with their characteristics:

- **round dots** ● ● (caution: do not confuse with circular screening: ©). This is appropriate for saturation values of up to approximately 70%. Above that value, the distance between neighbouring dots will be too low, and the points will join on four sides. This will result in a saturation shift and abrupt changes from light hues to dark hues. A further increase in the saturation would result in the soaking of the screening and an immediate shift to 100% saturation.

- **square dots** (chequered pattern ■ ■). This type will give the same effect at 50% saturation when neighbouring dots come into contact at four corners simultaneously. An abrupt shift in shade is easily noticeable to the naked eye and has a disruptive effect on the visual quality of the print.

- **ellipsoidal dots** (chain pattern ● ●). The same effect will occur with this type of screening dot as well. The effect however takes place in two phases. First, at around 40% saturation, the oblong sides of the dot come into contact; in the second phase, around 80% saturation, the short sides join as well.



This joining in two phases attenuates the salience of the shifts, which is less noticeable to the naked eye. Upon further saturation increase, the dots gradually overlap and the shade transition is smoother than with the preceding two dot shapes.

For silk-screening, the most appropriate dot type is the **autotypic ellipsoid 70/30 dot**. Round dots are not recommended. Square dots are forbidden.

4. Film density:

The density of the film is an expression of the shade of the black emulsion on the print-on. The density must be above 3.0, since lower values will cause the dots to appear as translucent grey spots.

5. Orientation of the emulsion on the film (print-on).

The emulsion on the film (print-on) must be applied on the readable side: this side of the film is pressed onto the silk-screen stencil so as to allow for a perfect transfer of the image during the printing in the exposure unit.

6. Printable area:

The areas of print for individual types of mediums are shown in the figures 1 to 6.

Medium type	Minimal diameter	Maximal diameter	Interruption
CD	19 mm	118 mm	24-26 mm
8 cm CD	19 mm	78 mm	24-26 mm
Business card	19 mm	minimum bleed 2 mm	24-26 mm
DVD 5	19 mm	118 mm	-
DVD 9	19 mm	118 mm	-

Advice: When processing print-ons in the DTP studio for two- or more colour printing, you should provide colour trapping parameters to ensure an accurate registration.

8. Parameters of the colour trapping:

- **0.05 mm** – recommended
- values above 0,05 mm are not recommended
- at 0 mm value any problems can occur with registration and the background may be visible

9. Half-tone printing

Screening density: 48 l/cm = 120 lpi
 Type of dots: autotypic 70/30 ellipsoidal
 Density range: 15% to 85%

Ruling: 45°

For duplex: 0°
 45° for the pre dominant colour

For triplex: 0° (or 90°)
 30°
 60°

For good results of printing, you must observe a ruling of 30° between the colours.

10. Four-colour printing **C, M, Y, K**

Screening: 48 l/cm = 120 lpi
 Type of dots: autotypic 70/30 ellipsoidal
 Density range: 15% to 85%

Ruling: the ruling depends on the predominant colour. That colour must be rotated to 45° or 135°, because a half-tone appearing at that angle is least visible (prominent) for the human eye.

		K predominant				
System		C	M	Y	K	
90 °		75°	15°	0°	45°	
180°		75°	15°	0°	135°	
		C predominant				
	C	M	Y	K		
90 °	45°	15°	0°	75°	Green, turquoise hues are dominated by Y, C	
180°	135°	75°	0°	15°		
		M Dominant				
	C	M	Y	K		
90°	75°	45°	0°	15°	Orange hues are dominated by Y, M	

180° 75° 135° 0° 15°

Yellow **Y** is not so predominant a colour and its half-tones will not disrupt the image, therefore it is not necessary to rotate the yellow plate.

No pair of colours should form a 90° angle.

At different ruling values, the “moiré” effects may markedly occur.

If the CMYK print is to appear over a white background, the print-on thereof must be planned and provided consistently with the print-ons of the other elements (mask, cut-out of the unprinted area)

Important: Always check the films for moiré patterns !!!!!!!

We need a print sample to attain good results of the printing (Chromalin, Matchprint, Pressmatch, sample CD etc.). The print sample is used only as an orientation point. Such prints as Chromalin, for instance, were developed for offset printing. We therefore cannot guarantee a complete colour match between the sample print and the CD label.

Advice:

The printing by means of the CMYK print in silk-screen printing is absolutely unsuitable, if large surfaces with one colour (for example the elementary background colour) occur on the printing. We are not able to guarantee the uniform colour scheme on the whole surface, as well as the overall colours' correspondence to the artwork. In case the printing consists maximally of 5 colours, we prefer to define these colours by means of the colours' scale PANTONE or HKS/K (see below) in the silk-screen printing (in contrast to the offset printing). Please, do not use in this case the break-up into C, M, Y, K.

11. Colour definition

For spot-colour printing we use the “PANTONE” Matching System colour scale and the HKS/K system. Colour shades requests must therefore be formulated in accordance with those colour systems.

Warning! *The stability of the colours of the samplers is guaranteed by the manufacturer for one year only. After one year the sampler must be replaced.*

All ink suppliers provide colour recipes for working on a silver background (directly on the CD) and for a screen with 150 fibres/cm, assuming standard light by the D65 standard. It is necessary to take this into account when using colour shades on a CD label with a white background, or on a CD with a golden metal layer: variations are to be expected from the originally intended mixed colour shades. If the mixed colour shade is observed under a light that is markedly different from D65, the colour shade may appear to be lighter or darker.

Warning!

A general colour may not be requested (e.g. from a sample object, from a print, etc.). We cannot guarantee the accuracy of a mixed colour shade, nor its repeated execution (e.g. in reprints). For that reason, when taking orders with "general" colours we use the nearest colour in the PANTONE scale.

12. Register marks

When preparing the print-ons for the stencils and to properly start the printing, you must place registration marks to ensure the correct registration of the plates. The standard position of the marks is represented on Figure No. 3.

Business cards require a special disposition of the registration marks (see Figures No. 3 and 4). Moreover, a blank zone is needed to place our orientation marks needed for operating the cutting lathes.

Warning

Do not place any indication on the label's printable area (e.g. on the film when preparing half-labels) unless that information is to appear on the CD. Every element of the printable area will be transferred onto the CD.

13. Identification of the sources

You must indicate on each print-on: the number of the order, the colour code, the screening data (LPI and ruling angle), the grey balance, the registration marks. All of this must appear outside the printing area.

IMPORTANT!!!!
ALL MATERIALS REQUIRED FOR THE PRODUCTION (data, sources data for the printed matters and printing) MUST BE PROVIDED TOGETHER AND IN APPROPRIATE QUALITY. OTHERWISE WE CANNOT GUARANTEE THE KEEPING OF THE AGREED TIME OF DELIVERY.

Technical specifications – offset

The offset printing enables to print the CDs and DVDs of the same types as mentioned in the following enclosures (type A, type B, DVD9, DVD10 and DVD5 – both variants). It is impossible to print the business cards with the ring on the offset printing machine (the only possibility is represented by the business card manufactured from an 8mm CD).

Configuration of the machine:

- silk-screen printing station (it is usually used for the print of the background white colour)
- colour-print part of the machine – the offset itself, it prints with the CMYK colour-print (the screening is 175 LPI)
- silk-screen printing station (in the case of need it is possible to use it for the varnishing by means of a clear gloss/mat varnish or for the print of a direct PMS colour.

Warning:

The printing by means of the CMYK print in silk-screen printing is absolutely unsuitable, if large surfaces with one colour (for example the elementary background colour) occur on the printing. We are not able to guarantee the uniform colour scheme on the whole surface, as well as the overall colours' correspondence to the artwork. In this case we recommend the conversion of such surface into a direct colour and to use for its print the silk-screen printing station at the machine output port.

Specifikace potisku CD - TYP A

potisk pouze na pokovené oblasti - doporučeno

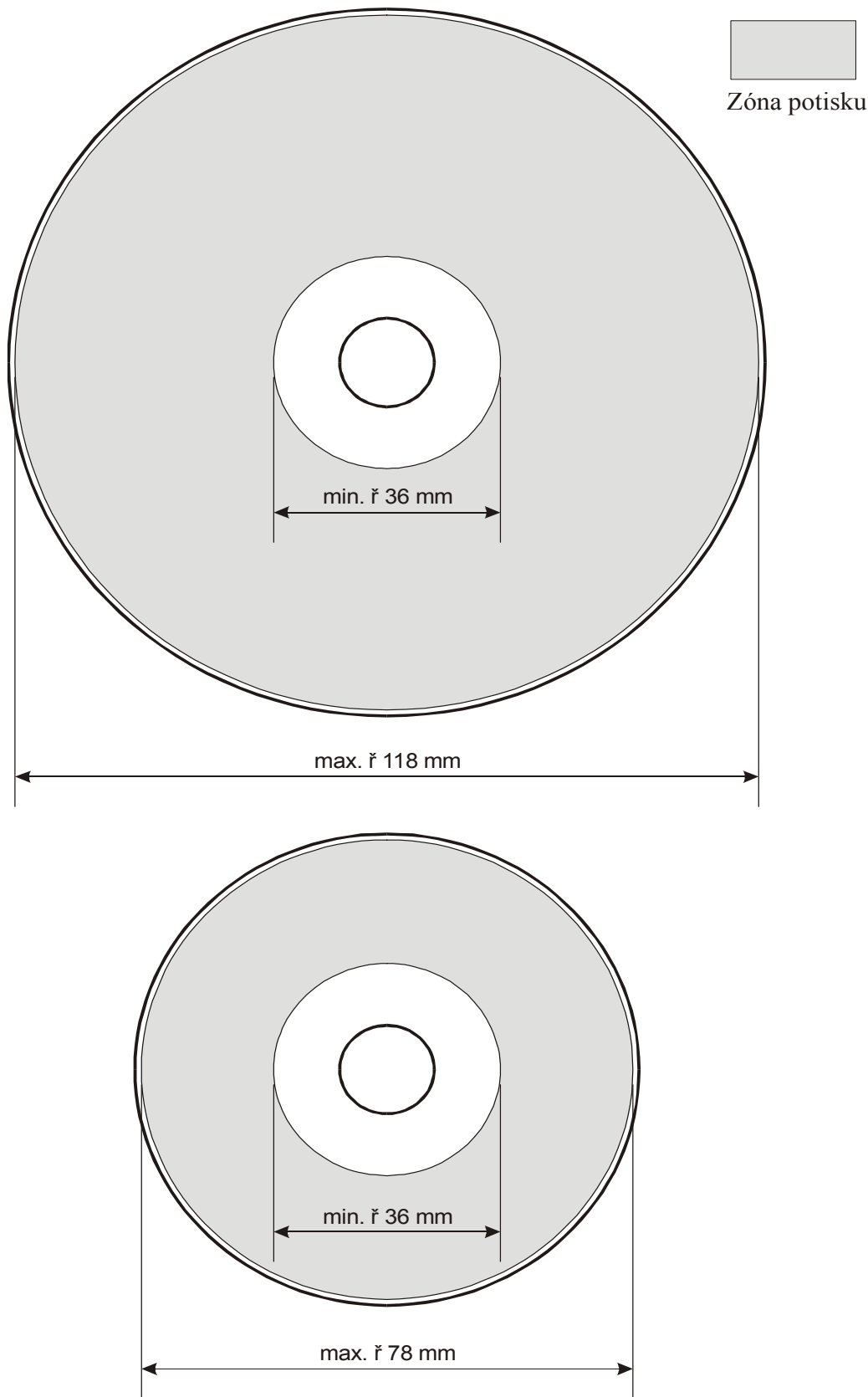

Figure No. 1

CD label specification – TYPE A

label area covering only the metal layer – recommended

label area

Specifikace potisku CD - TYP B

potisk na pokovené i nepokovené oblasti

Upozornění:

V oblasti s pokovením a bez pokovení dochází k barevné odchylce. Pro její minimalizaci doporučujeme použít jako podklad bílou barvu.

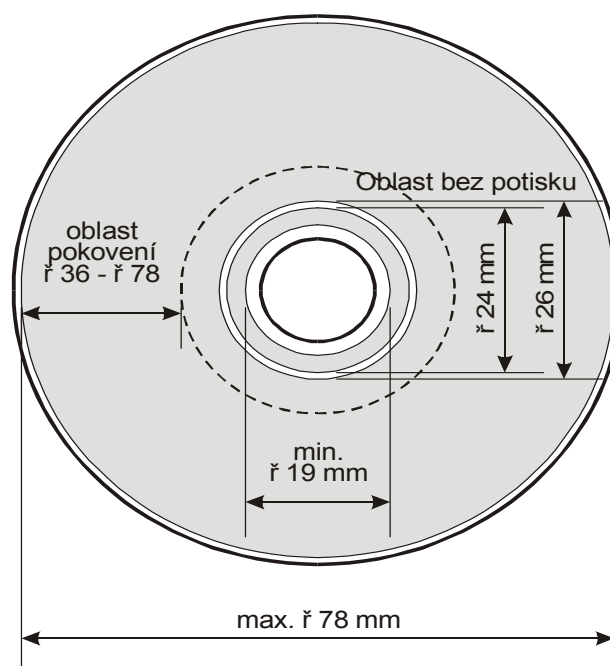
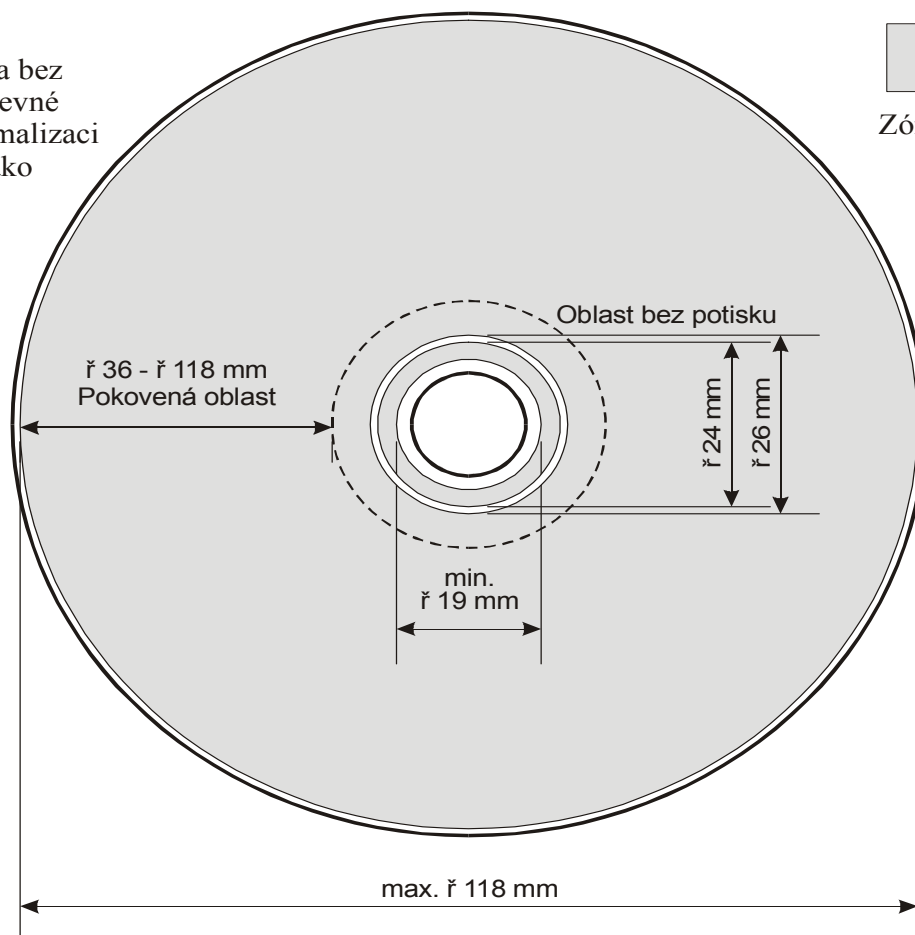
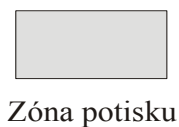

Netisknutelná oblast
 < ř 19 mm
 ř 24 až ř 26 mm
 > ř 118 mm

Figure No. 2

CD label specification – TYPE B

label area covering both the metal and the non-metal layer

label area

Advice:

Colour shifts will occur between the area of the metal layer and the transparent centre of the disc. To minimise that effect, we recommend the use of a white background.

Metal layer area

Non-printing area

CD vizitka velká - specifikace potisku

9:33 minuty hudby nebo 88 MB dat

Důležité:

Pro přesné umístění potisku na vizitku vyznačte střed tisku registračním křížem. Délka linky 10 mm, tloušťka 0,1 až 0,2 mm.

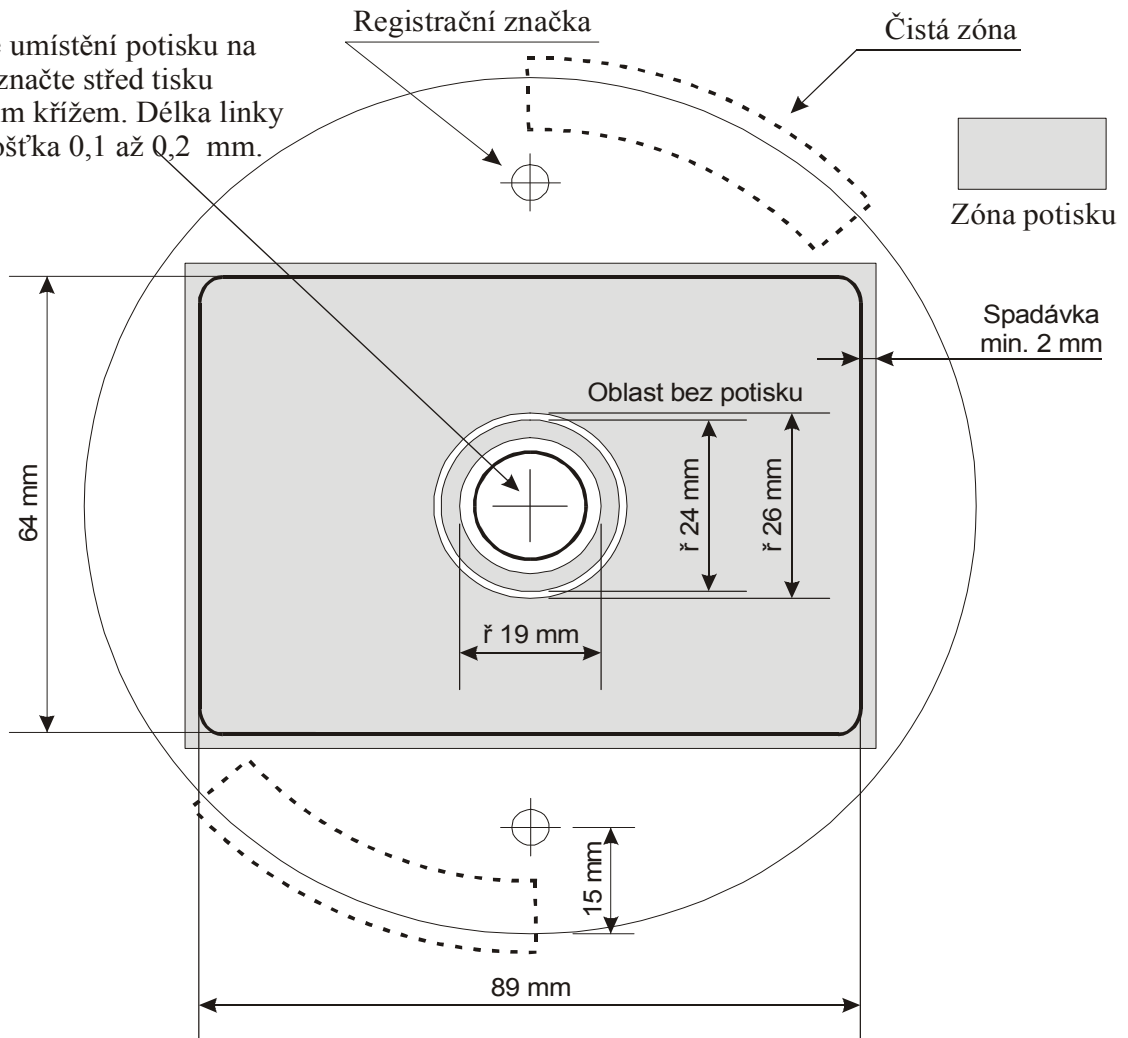

Figure No. 3

Large CD business card - label specifications

9:33 minutes of music or 88 MB of data

Important:

Mark the centre of the card with a registration cross mark to help positioning of the label; length of line 10 mm, weight 0.1 to 0.2 mm.

Registration mark

Non-printing area

Empty zone

Printing area
Bleed

CD vizitka malá - specifikace potisku

2:51 minut hudby nebo 26,3 MB dat

Důležité:

Pro přesné umístění potisku na vizitku vyznačte střed tisku registračním křížem. Délka linky 10 mm, tloušťka 0,1 až 0,2 mm.

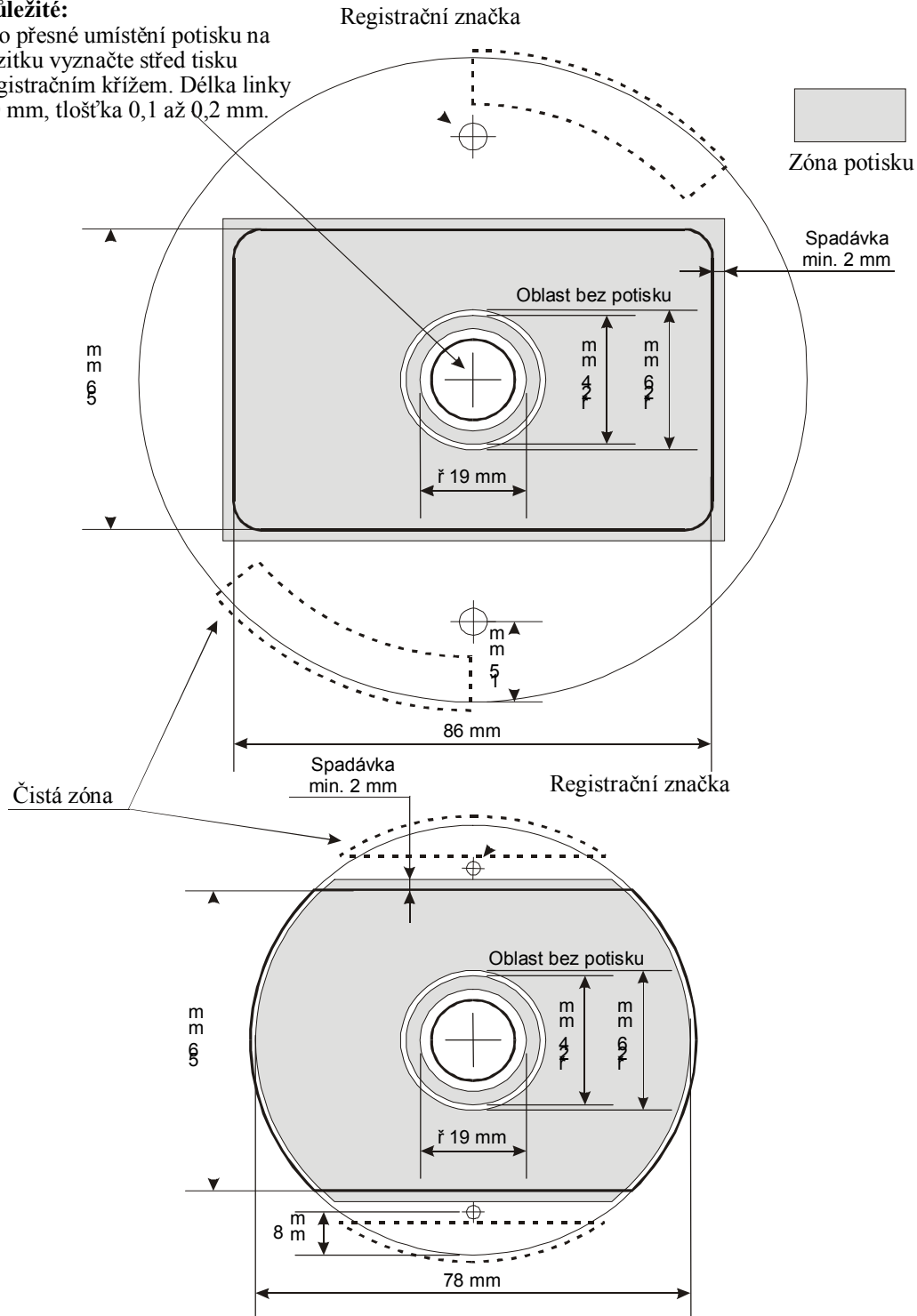

Figure No. 4

Small CD business card - label specifications

2:51 minutes of music or 26.3 MB of data

Important:

Mark the centre of the card with a registration cross mark to help positioning of the label; length of line 10 mm, weight 0.1 to 0.2 mm.

Registration mark

Non-printing area

Empty zone

Printing area
Bleed

Specifikace potisku DVD 9

Upozornění:

V oblasti s pokovením a bez pokovení dochází k barevné odchylce. Pro její minimalizaci doporučujeme použít jako podklad bílou barvu.



Zóna potisku

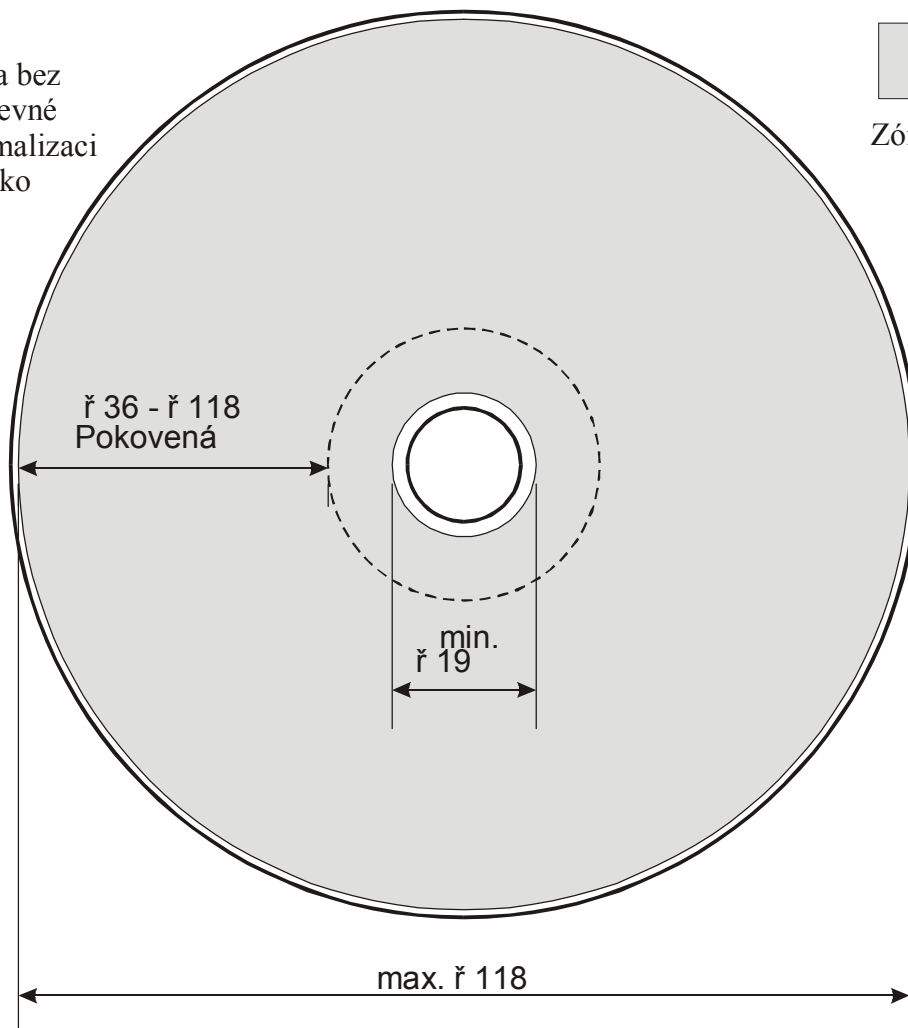

Figure No. 5
DVD 9 label specification

label area

Advice:

Colour shifts will occur between the area of the metal layer and the transparent centre of the disc. To minimise that effect, we recommend the use of a white background.

Metal layer area

Specifikace potisku DVD 10

tisk pouze na straně 2

Upozornění:

V oblasti s pokovením a bez pokovení dochází k barevné odchylce. Pro její minimalizaci doporučujeme použít jako podklad bílou barvu.

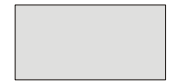

Zóna potisku

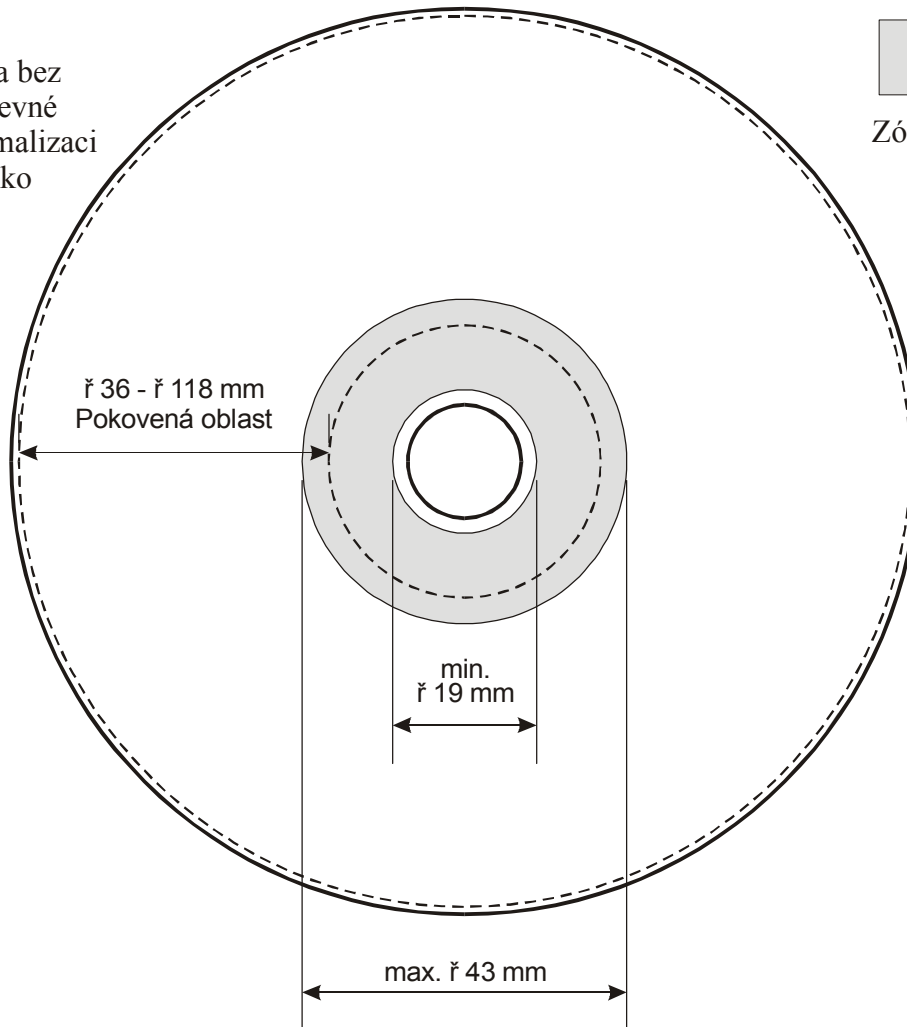

Figure No. 6

DVD 10 label specification

The print only on side 2

label area

Advice:

Colour shifts will occur between the area of the metal layer and the transparent centre of the disc. To minimise that effect, we recommend the use of a white background.

Metal layer area

Registration marks positioning

Line weight of the registration marks 0.1 mm

Umístění registračních značek

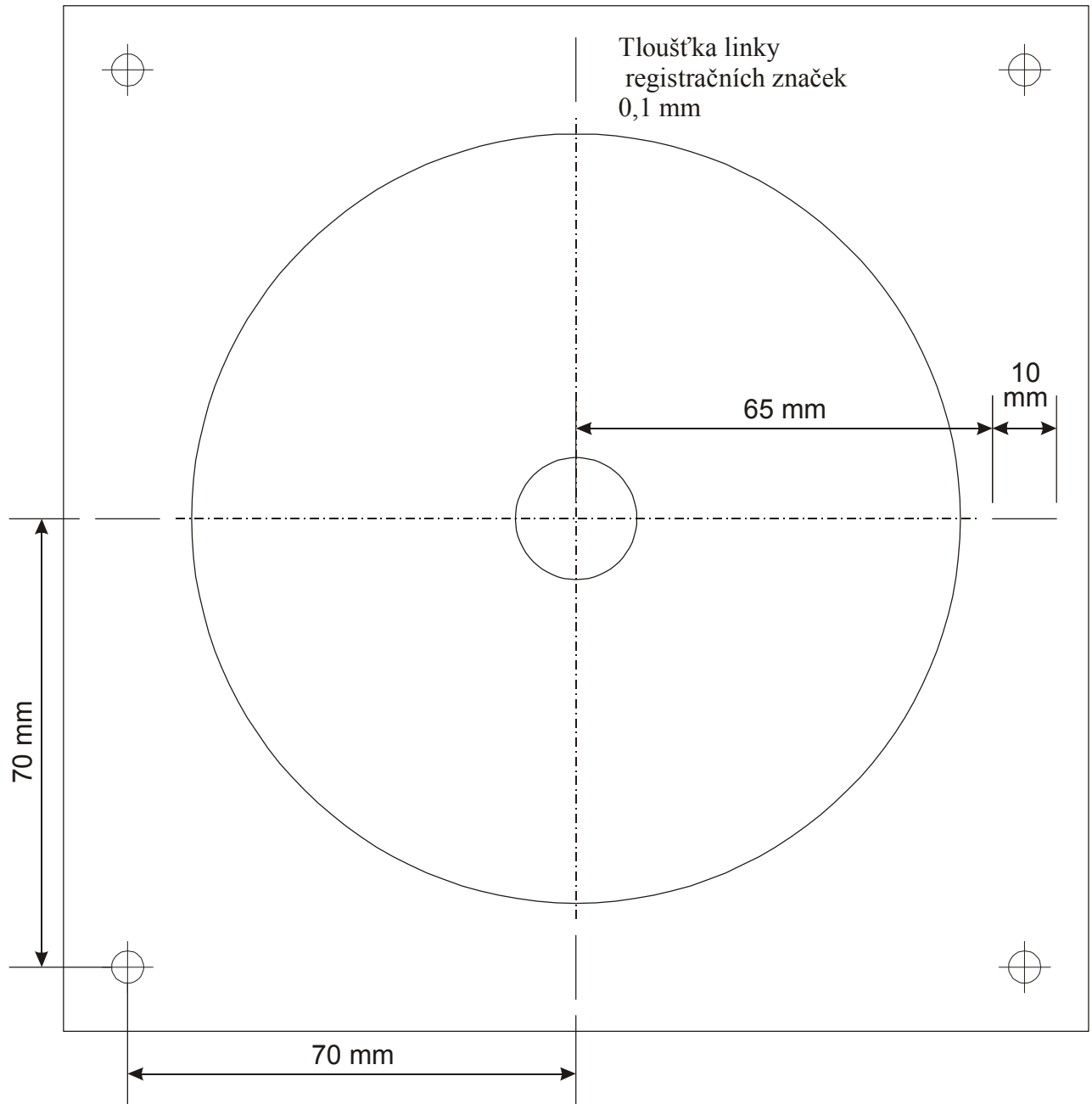

Figure No. 7

DVD5 LABEL – variant 1.

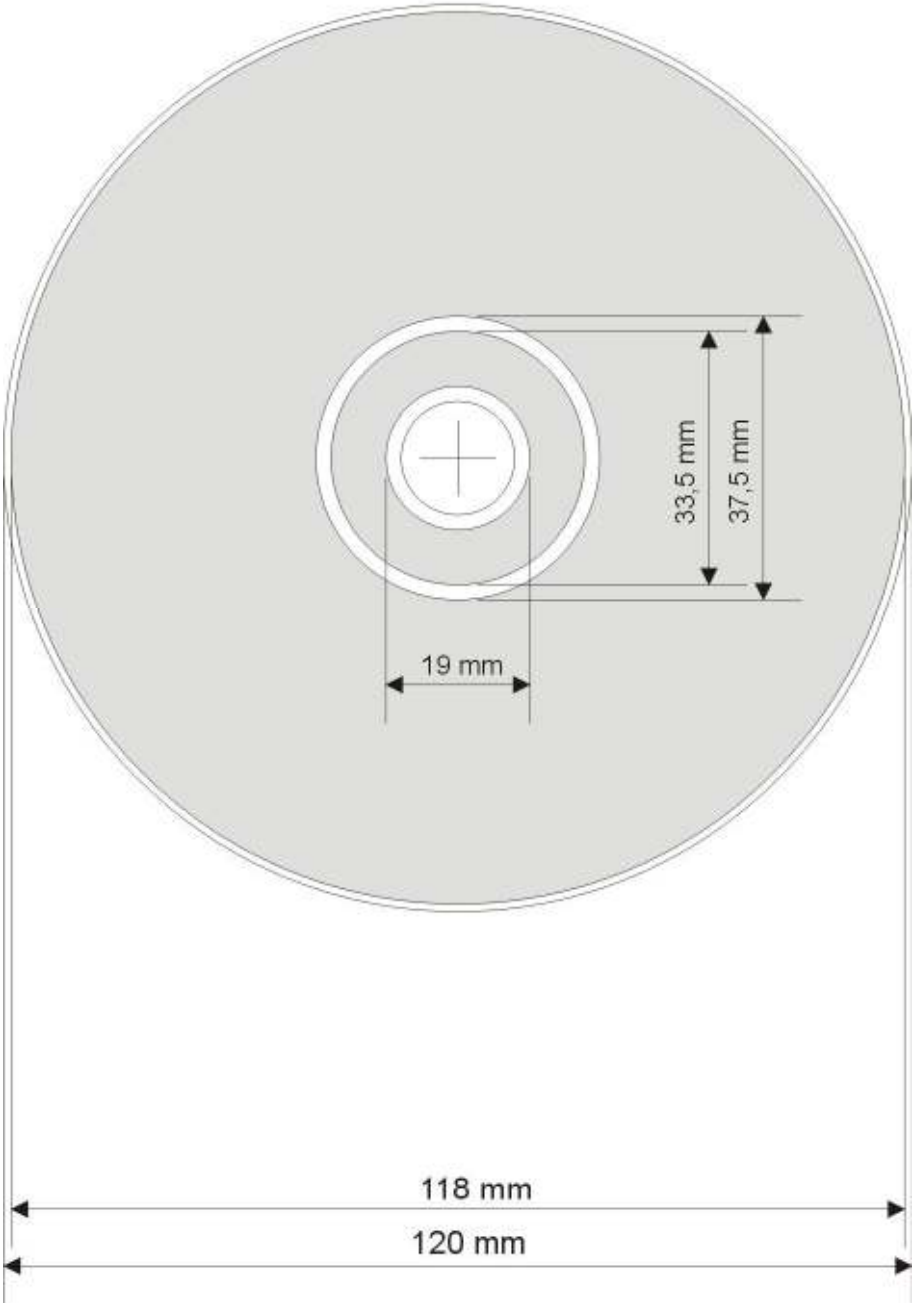

Figure No. 8

DVD5 LABEL – variant 2.

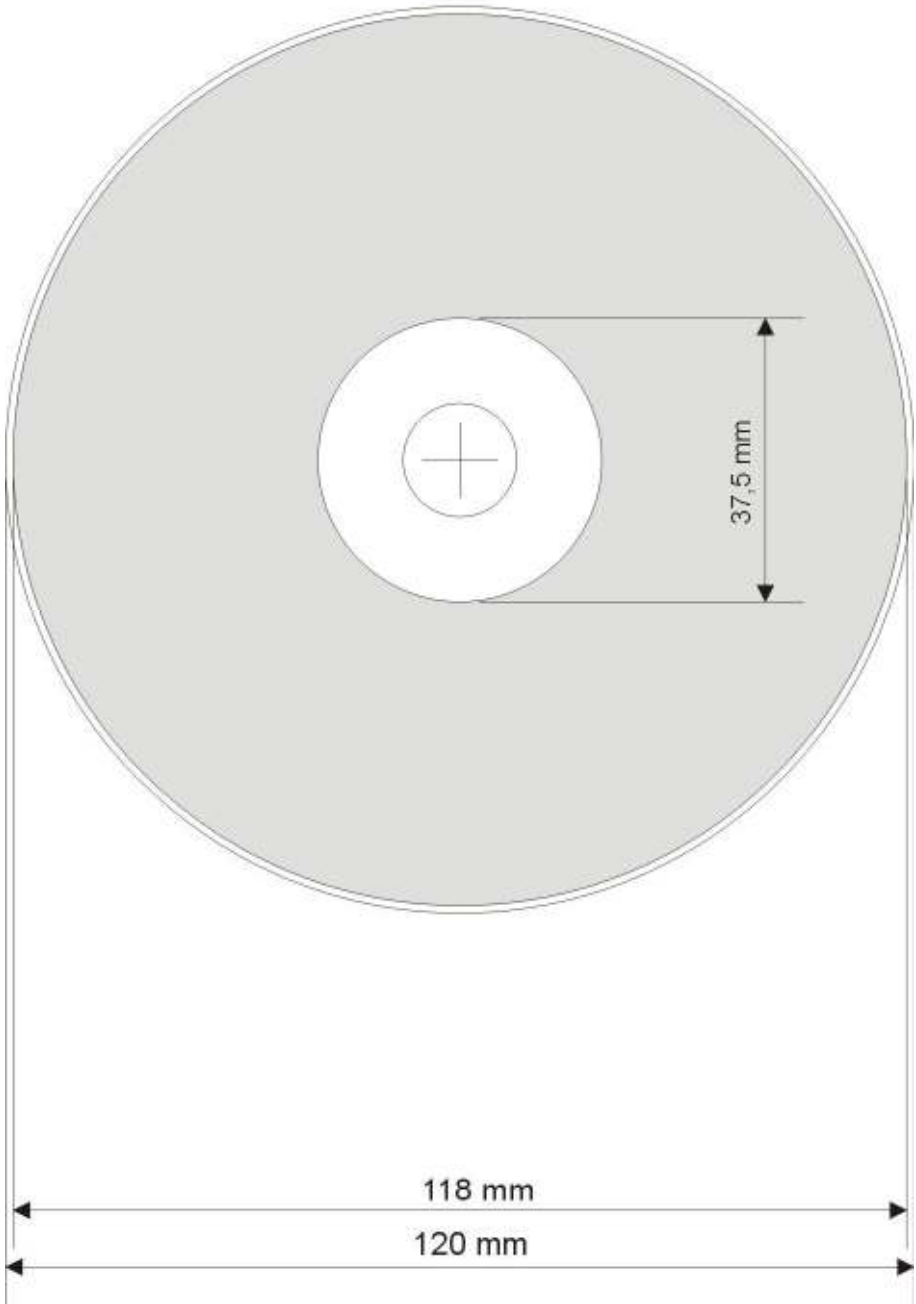

Figure No. 9